

STRAIGHT BULKHEAD JACK PANEL SEAL
SOLDER TYPE - CABLE .250

R161.337.200
SERIES N

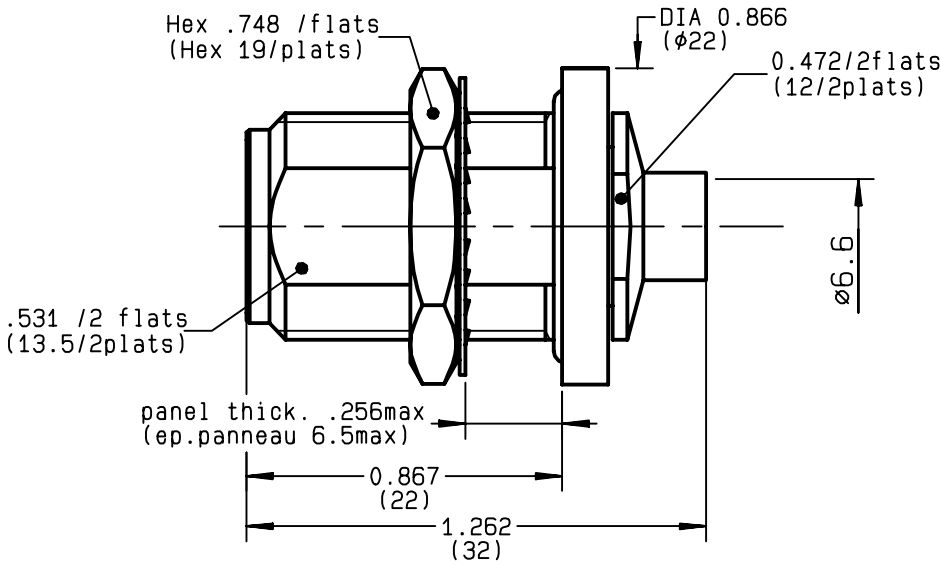

PERCAGE PANNEAU
MOUNTING HOLE

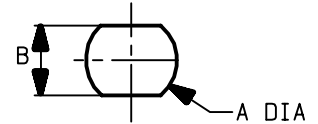

	MM		INCH	
	maxi	mini	maxi	mini
A	16.1	16	0.634	0.63
B	13.7	13.6	0.539	0.535

NOMINAL IMPEDANCE	50	Ω
FREQUENCY RANGE	0-11	GHz
TEMPERATURE RATING	-55/+105	$^{\circ}C$
V.S.W.R	1.25 +	x F(GHz)Maxi
RF INSERTION LOSS	0.048	\sqrt{F} (GHz) dB Maxi
VOLTAGE RATING	1400	Veff Maxi
DIELECTRIC WITHSTANDING VOLTAGE	2500	Veff Mini
INSULATION RESISTANCE	5000	M Ω Mini
HERMETIC SEAL	NA	Atm.cm ³ /s
LEAKAGE (pressurized only)	IP 67	
MECHANICAL DURABILITY	500	Cycles
WEIGHT	35	gr
SPECIFICATION		

CABLES : **KS 3**
RG 401

OTHERS CHARACTERISTICS

CABLE RETENTION	500	N Mini
CENTER CONTACT RETENTION		
Axial force - mating end	NA	N Mini
Axial force - opposite end	NA	N Mini
Torque	NA	cm.N Mini
RECOMMENDED TORQUES		
Mating	NA	cm.N
Panel nut	500	cm.N
Clamp nut	150	cm.N

CONNECTOR PARTS	MATERIALS	FINISH	(all values are given in micrometers)
BODY	BRASS	BBR 2	
OUTER CONTACT			
CENTER CONTACT	BERYLLIUM COPPER	GOLD 0.5 OVER NICKEL 2	
INSULATOR	PTFE	-	
GASKET	SILICONE RUBBER	-	
OTHERS PIECES	BRASS	BBR 2	

ISSUE	CREATION DATE	FILE PART-NUMBER
9850A00	06/02/1997	EPC 96-07



GONZALES

The information given here is subject to change without notice.
Design changes may be in order to improve the product .

Connect to the future



R161.337.200

ISSUE **9850A00** SERIES **N**

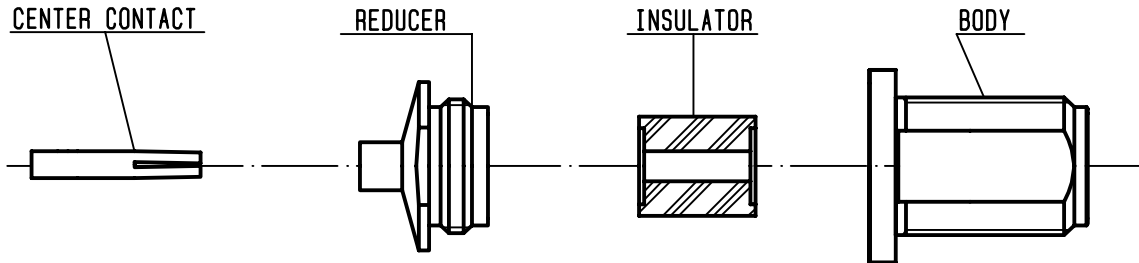

①

Take the tool kit : R 282 125 010 .
Strip the dielectric of the cable .
Stripping tool cable : R 282 054 .
Trimmer : R 282 074 020 .
Clean the cable .

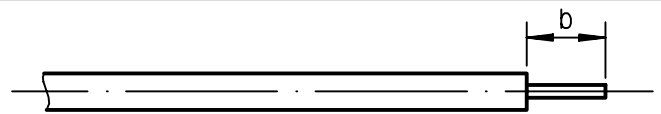

Stripping	a	b	c	d	e
inch	0	0.177 0	0	0	0
mm		4.5			

②

Screw the positioner R282 744 260 onto the soldering jig R 282 740 030 .
Slide contact into positioner .
Insert solder gauge R 282 862 080 between contact and cable .
Tighten and solder the contact .

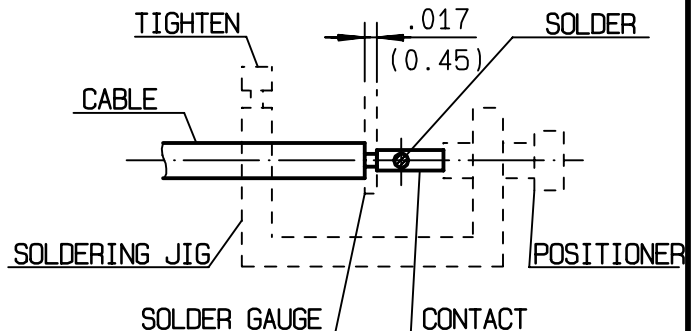

③

After cooling remove cable assembly from the jig .
Put positioner R282 744 310 on the soldering jig .
Slide cable into the reducer until it bottoms against positioner R282 744 310 .
Tighten .
Put 3 rings of solder around the cable and solder .

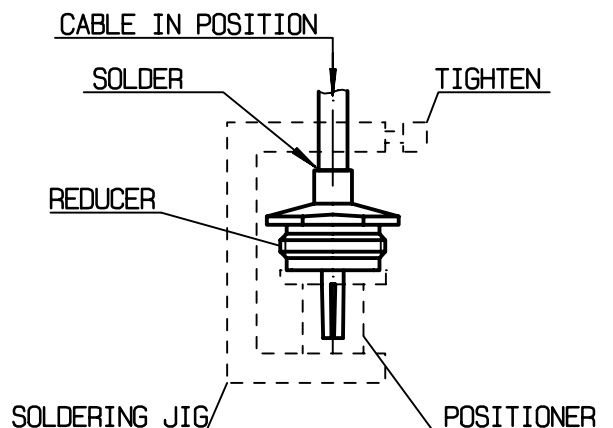

④

After cooling remove cable assembly from the jig .
Slide insulator into the centre contact .
Screw sub-assembly into the connector body .
(recommended coupling torque 13.27 in.lb)

